

REVISIONS				
REV.	DESCRIPTION	DATE	ECN	INITIAL
A	INITIAL RELEASE	1/21/21	3764	ARG
B	UPDATE BODY DIAMETER	09/07/22	4105	MRA

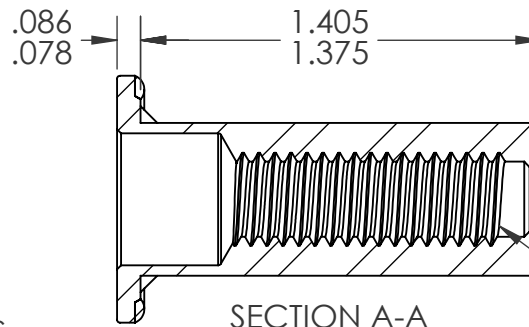
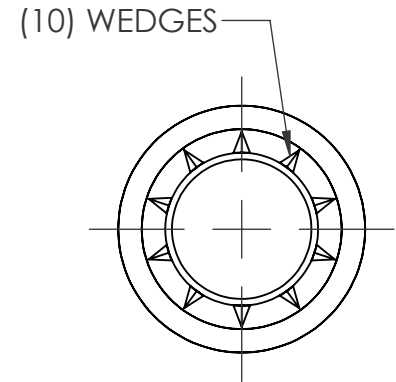
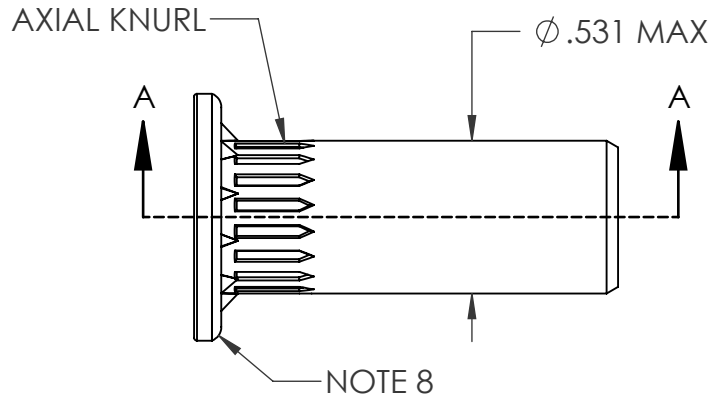
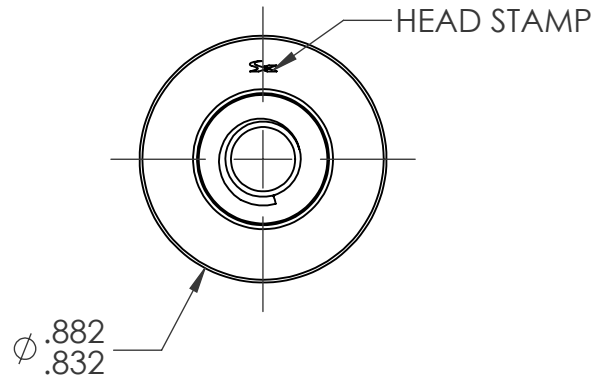

SECTION A-A  
SCALE 1.5 : 1

5/16-18 UNC 2B  
PER ASME B1.1  
MINOR DIA.: .252 - .265

**NOTE:**

- GRIP RANGE: 0.059 - 0.138
- HOLE SIZE: .532 +.006/-.000 AFTER ALL APPLIED FINISHES.
- INSTALLED LENGTH: 1.181 MAX
- INSTALLED THREAD DEPTH: 1.063 MIN. IN MIN. GRIP
- LUBRICATION: NONE
- INSTALLATION TOOL: SPIN-PULL
- THREADS MEET GRADE 5 PROOF LOAD: 6950lbf PER SAE J995
- DEPOSIT PLASTISOL ALONG OUTER GROOVE OF THE HEAD.  
SEAL MUST NOT CONTACT THE WEDGES.

**PROPRIETARY AND CONFIDENTIAL**

THIS DRAWING, AND THE INFORMATION CONTAINED HEREIN, ARE THE PROPERTY OF SHEREX AND ARE NOT TO BE USED IN ANY MANNER DETRIMENTAL TO THE INTEREST OF THE COMPANY.  
SHEREX SOLUTIONS RESERVES THE RIGHT TO REVISE PART/DRAWING WITHOUT NOTICE.

		UNLESS OTHERWISE SPECIFIED:	NAME	DATE
		DIMENSIONS ARE IN INCHES TOLERANCES: ANGULAR: MACH $\pm 1$ BEND $\pm 1$ TWO PLACE DECIMAL $\pm .01$ THREE PLACE DECIMAL $\pm .002$	DRAWN	ARG 1/21/21
		INTERPRET GEOMETRIC TOLERANCING PER: ASME Y14.5M-1994	CHECKED	
		MATERIAL	ENG APPR.	CL 1/21/21
		C1008/C1010 STEEL	MFG APPR.	
		FINISH	Q.A.	
		ZINC PLATE CLEAR TRIVALENT CHROMATE PER SFS-01-001, SC1	COMMENTS:	
NEXT ASSY	USED ON		E-mail: info@sherex.com	
			www.sherex.com	
			Phone: 866-474-3739	
			Fax: 716-875-0358	
APPLICATION		DO NOT SCALE DRAWING		



**TITLE:**

5/16 - 18 CLOSED END LARGE FLANGE OPTISERT W/ SEAL

SIZE DWG. NO.

**A** OPT2-3118-138BS

REV

**B**

SCALE: 2:1 WEIGHT:

SHEET 1 OF 1